

**Liquid Ring Compressors
Engineered-to-Order Compressor Systems**

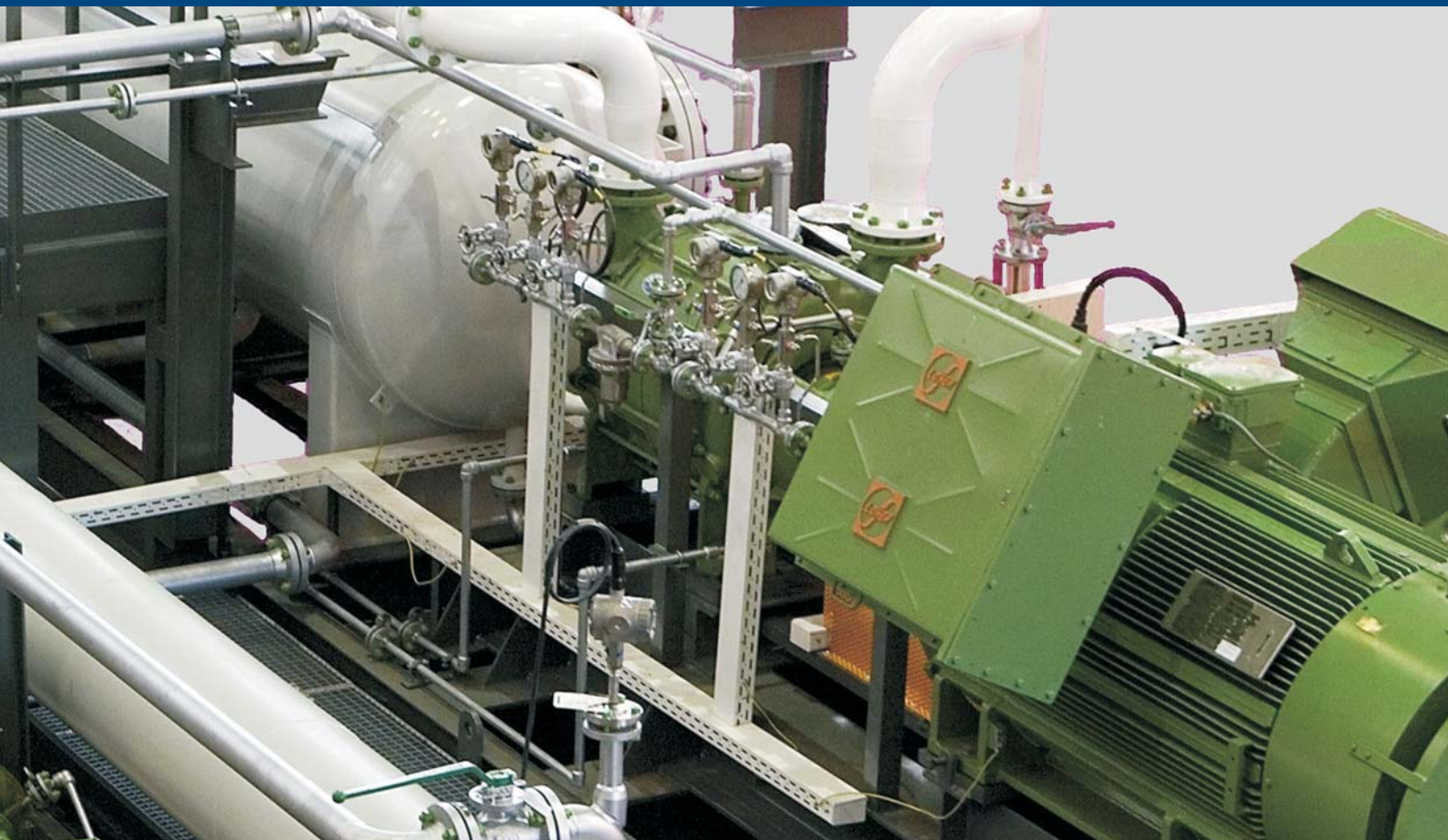

NASH Liquid Ring Compressors

Greatest Performance Range of Liquid Ring Compressors Worldwide

The ability to compress wet, saturated or dirty gases is essential in many industrial applications. To deal with these challenges, liquid ring compressors are the number one choice. Due to the liquid ring technology, they can handle highly toxic, explosive and corrosive gases.

Nash provides its customers with reliable, quality liquid ring compressors with the features and performance necessary for all demanding applications. Whether it is flare gas compression, Vinyl Chloride Monomer (VCM) recovery or any other type of wet, corrosive, dirty or explosive gas, the Nash product range can provide the right solution. Models are available as single and two stage compressors.

To deal with these process challenges, Nash compressors are available in a wide variety of materials. Of course, stainless steel is the first material of choice, but these rugged machines can also be built in other sophisticated materials.

Nash products cover the greatest performance range of all liquid ring compressors worldwide. Depending on the machine and application, these compressors work on discharge pressures up to 15 bar abs. with a suction capacity of 1,500 m³/h or with a suction capacity of 16,000 m³/h, compressing gas to 2 bar abs. With more than 100 years of experience, Nash will find the right compressor for your application.

Nash Liquid Ring Compressors require minimal care and are known for an extremely low need for maintenance. They reduce power and operating costs by handling higher capacities with less energy.

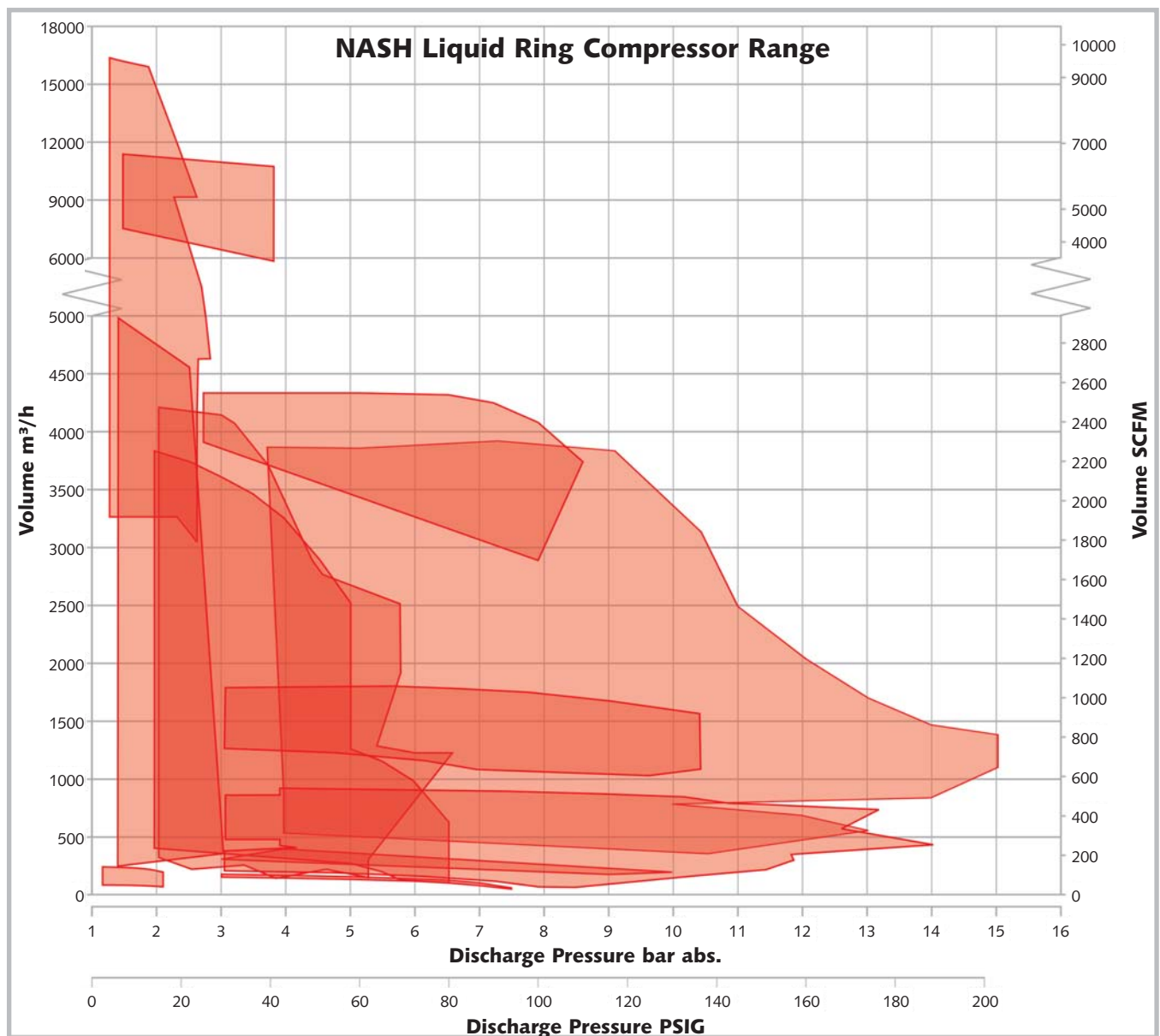

NASH Liquid Ring Compressors

High Pressure Liquid Ring Compressors

NASH HP-9

Found primarily in petroleum refineries and chemical plants, these rugged and reliable compressors handle

highly toxic, explosive and corrosive gases in applications such as flare gas and Vinyl Chloride Monomer (VCM) recovery.



NASH HP-9



NASH NAM

Basic specifications NASH HP-9 (single stage compressor)	
Suction capacity	3,000 to 4,300 m ³ /h 1,800 to 2,500 CFM
Discharge pressure	to 8 bar abs. 100 psig
Mechanical seal	Single, double, cartridge
Construction materials	Stainless steel; other materials optional

Basic specifications	NASH NAM (single stage compressor)	NASH NAB (two stage compressor)
Suction capacity	100 to 3,600 m ³ /h 60 to 2,100 CFM	100 to 2,600 m ³ /h 60 to 1,500 CFM
Discharge pressure	to 6 bar abs. 72 psig	to 15 bar abs 200 psig
Mechanical seal	Single, double, cartridge	
Construction materials	Stainless steel; other materials optional	

NASH NAM/NAB

These high pressure liquid ring compressors are built for highly toxic, explosive and corrosive processes as well. They can handle dry and wet chlorine, ethylene, H₂S, and many other condensable and non-condensable gases.

NAM - Single Stage Compressor NAB - Two Stage Compressor

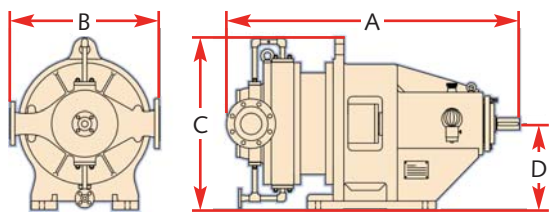

HP-9 - Single Stage Compressor

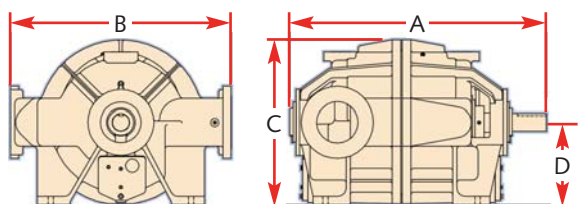

Dimensions all dimensions are approximate

Pump Model	A mm inches	B mm inches	C mm inches	D mm inches	Gas Inlet Flange mm inches	Gas Discharge Flange mm inches
NAM 400	1180 46.46	700 27.56	31.5 800	400 15.75	100 4	80 3
NAM 600	1245 49	700 27.56	31.5 800	400 15.75	100 4	80 3
NAM 850	1274 50.17	700 27.56	31.5 800	400 15.75	100 4	80 3
NAM 900	1463 57.59	690 27.17	31.5 800	400 15.75	150 6	100 4
NAM 1100	1353 53.25	750 29.53	31.5 800	400 15.75	150 6	100 4
NAM 1500	1905 75	900 35.43	980 38.58	500 19.69	200 8	150 6
NAM 2500	1980 77.94	1000 39.37	1080 42.52	560 22.05	250 10	150 6
NAB 150	1005 39.56	450 17.72	515 20.27	250 9.84	65 2-1/2	40 1-1/2
NAB 250	1053 41.47	630 24.8	718 28.29	364 14.35	76 3	51 2
NAB 600	1370 53.92	700 27.56	800 31.5	400 15.75	100 4	80 3
NAB 850	1387 54.59	700 27.56	800 31.5	400 15.75	100 4	80 3
NAB 1100	1642 64.63	900 35.43	878 34.55	400 15.75	150 6	100 4
NAB 1500	1844 73.82	1000 39.37	1020 40.16	500 19.69	200 8	150 6
NAB 2500	2320 91.34	1000 39.37	1120 44.1	560 22.05	250 10	150 6
HP-9	1575 62	1372 54	1016 40	762 20	254 10	254 10



NASH Liquid Ring Compressors

Medium Pressure Liquid Ring Compressor



NASH 2BQ1

The world's first liquid ring compressors with high gas flow rates and discharge pressures of up to 3.75 bar abs.

The NASH 2BQ1 590 has a unique performance range. It combines a high gas flow rate with a discharge pressure range of up to 3.75 bar abs., providing high efficiency. The performance data of this machine is unmatched by any other liquid ring compressor on the market.

The NASH 2BQ1 is based on the proven, modular NASH 2BE3 series and was developed with improved compressor configuration. Standard 2BE3 components can be used in many areas as a result.

The rotor, shaft and bearings were strengthened in order to withstand higher pressures. The NASH 2BQ1 is also designed for a wide operating speed range (420 to 611 rpm).

The shaft and housing are solid stainless steel, as are the mechanical shaft seals. Since every component can be made with application-specific stainless steels, the NASH 2BQ1 the ideal liquid ring compressor for demanding process requirements. Applications include the recovery and compression of hydrocarbons and the compression of hydrogen, chlorine or other process gases.

The NASH 2BQ1 is certified for ATEX.

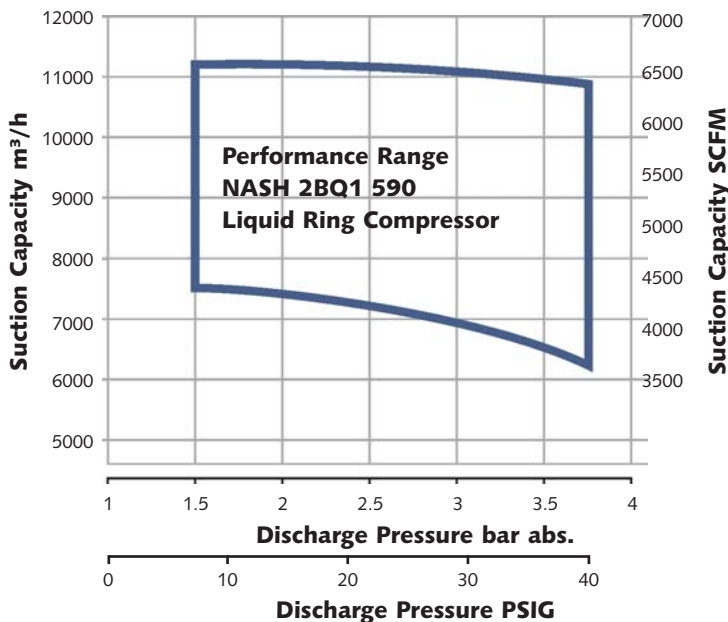
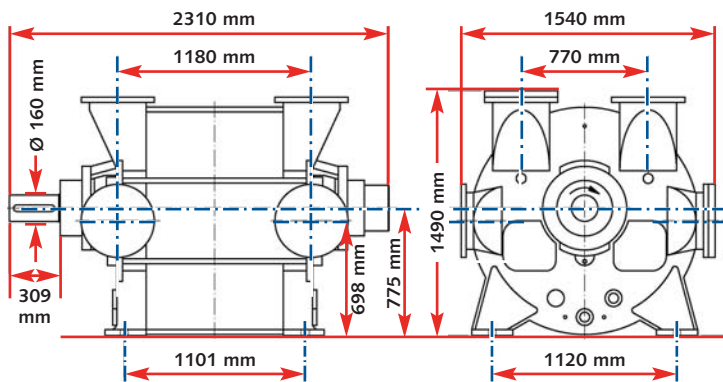

Basic Specifications NASH 2BQ1 590	
Suction capacity	6,000 - 11,000 m³/h 3,500 to 6,400 CFM
Suction pressure	0.8 - 1.5 bar abs. to 7 psig
Discharge pressure	1.5 - 3.75 bar abs. 7 - 40 psig
Construction materials	Ductile iron, stainless steel

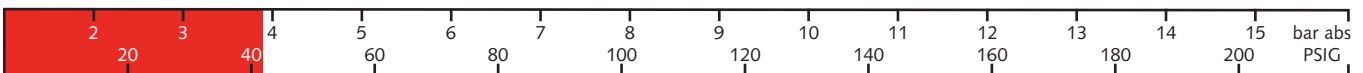

NASH Liquid Ring Compressors

Low Pressure Liquid Ring Compressors

NASH 2BE4

When it is about compressing large volumes of gas, NASH 2BE4 compressors are the ultimate choice.

These big machines are used for CO₂ compression in sugar mills, handle CO₂ with ammonia, compress coke oven

gases, and fulfill many duties in the chemical process industry and many other applications.

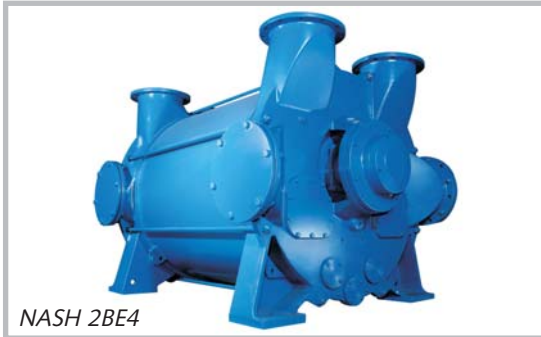

NASH 2BE4

Basic specifications NASH 2BE4 (Compressor)	
Suction capacity	5,000 to 30,000 m ³ /h 3,000 to 17,600 CFM
Discharge pressure	to 2.5 bar abs. 22 psig
Mechanical seals	Single, double (on request), stuffing box
Construction materials	Ductile iron, stainless steel, combination of both materials

NASH Vectra XL/GL

These rugged machines are usually found in the chemical process industry. They handle applications

like waste gas and flue gas compression as well as the compression of SO₂.

NASH Vectra XL compressors also work reliably in many other applications.



NASH Vectra XL

Basic specifications NASH Vectra XL (Compressor)	
Suction capacity	200 to 7,200 m ³ /h 120 to 4,300 CFM
Discharge pressure	to 3 bar abs. 30 psig
Mechanical seals	Single, double and cartridge
Construction materials	Ductile iron, stainless steel

NASH Vectra SX

Due to advanced design and high reliability, the NASH Vectra SX is the right choice for compressing low

volumes of gas up to low pressure. These highly efficient compressors are used for wastewater treatment, digester gas

compression, aeration, gas boosting and in many other applications and industries.



NASH Vectra SX

Basic specifications NASH Vectra SX (Compressor)	
Suction capacity	45 to 230 m ³ /h 26 to 140 CFM
Discharge pressure	to 2.3 bar abs. 20 psig
Mechanical seal	Single
Construction materials	<ul style="list-style-type: none"> Cast Iron with precision cast 316 SS Rotor & SS lined body All precision cast 316 SS

Most Nash vacuum pumps can also work as low pressure compressors. Please contact Nash for more information.

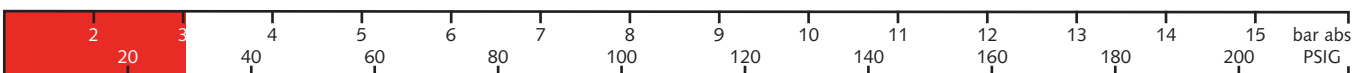

NASH Liquid Ring Compressor Systems

From Vacuum to Compression: Special Performance Compressors

Some applications require vacuum and compressor applications in one process. Instead of handling the gas with two separate

machines, Nash compressors can do the job with only one pump. This reduces the cost and simplifies the installation.



NASH 2BG Ozone Compressor

NASH 2BG

NASH 2BG two stage compressors have the ability to operate in processes that require both vacuum and compressor applications. These compressors work reliably in batch and continuous processes from 300 mbar abs. to 6 bar abs. They can reach even higher discharge pressures when operating with a pressurized inlet. NASH 2BG compressors are also the first choice for the compression of ozone.

NASH 2BK

NASH 2BK single stage compressors also function with negative and positive pressure inlets. These rugged compressors are relied on for the compression and recovery of hydrocarbons.

Basic specifications NASH 2BG (two stage)	
Suction capacity	50 to 1,750 m ³ /h 30 to 1,000 CFM
Suction pressure	0.3 - 2 bar abs. 9 inches of mercury - 15 psig
Discharge pressure	to 13 bar abs. 170 psig
Mechanical seal	Single or double, with external flushing supply
Construction materials	Stainless steel and other materials

Basic specifications NASH 2BK (single stage)	
Suction capacity	150 to 4,200 m ³ /h 90 to 2,450 CFM
Suction pressure	0.8 - 2 bar abs. 24 inches of mercury - 15 psig
Discharge pressure	to 6 bar abs. 75 psig
Mechanical seal	Single, with external flushing supply
Construction materials	Stainless steel and other materials

Demanding Compressor Applications



NASH HP-9 Flare Gas Recovery Unit

Nash liquid ring compressors handle wet, saturated or dirty gases in many industrial applications. They can also handle highly toxic, explosive and corrosive seal liquids. Thanks to sophisticated materials and decades of superior expertise, Nash compressors work in:

- H₂S Removal
- Dry and Wet Chlorine Compression
- Hydrogen Compression
- Hydrocarbon Recovery
- VCM Recovery
- Flare Gas Recovery
- Glycol Recovery
- Biogas Production

and many other demanding applications.



NASH Liquid Ring Compressor Systems

Engineered-to-Order Liquid Ring Compressor Systems



Unmatched experience

Nash liquid ring compressors are the heart of our engineered-to-order compressor systems. Having built these rugged machines for nearly a century, we have unmatched experience in engineering custom-made liquid ring compressor systems for almost every application. Applying our know-how to our machines and systems provides superior value for our customers. Gardner Denver Nash is the leader of the field.

Every process is different

There are unique requirements for every compressor system, whether it regards limited space requirements, gases and liquids used in a batch or continuous process or specialized instrumentation. We design your compressor system to match your requirements using state-of-the-art 3D CAD software.



Highest standards

Gardner Denver Nash is committed to the highest standards in production and safety. We have many ISO certificates, issued to Nash facilities worldwide. We continuously improve our quality by optimizing our internal processes.

NASH compressors are certified to ATEX and other global industrial standards. Our global network of service and support is always available to keep your system running for years.

Features	Benefits
Ability to handle carryover	Minimal process problems resulting in more uptime; intended for severe applications
Long design life of 40+ years	Highest reliability
No internal lubrication required	Less maintenance required; less downtime
No metal-to-metal contact	Constant wear-free performance
Cool Running, minimal temperature rise between inlet and discharge	Ideal for explosive gases and vapor recovery applications
Only one moving part	Simple and reliable operation

Other NASH Products:

2BE4 / P2620

Large liquid ring vacuum pumps with superior corrosion resistance
Top discharge capability which eliminates need for trench
Self-recirculating seal water, reducing need for external seal water source
Capacity of 6,800 to 39,000 m³/h with vacuum to 160 mbar abs
Capacity of 4,000 to 23,000 CFM with vacuum to 25" HgV



Vectra XL, GL Vectra SX

Liquid ring vacuum pumps and compressors
Available in feature rich budget designs (SX, XL or GL)
Designed to handle high back pressure requirements
Capacity of 34 to 6,796 m³/h with vacuum to 33 mbar abs
Capacity of 20 to 4,000 CFM with vacuum to 29+ HgV



TC/TCM

Integral 2 stage liquid ring pumps with improved performance at vacuum levels down to 27 mbar (0.8" HgA)
Designed to handle large amounts of liquid carryover without difficulty
Capacity of 170 to 3,740 m³/h with vacuum to 27 mbar abs
Capacity of 100 to 2,240 CFM with vacuum to 0.8" HgA



Steam Jet Ejectors

Sizes range from 25mm (one-inch) to 2 meters (78-inch) inlets
Capacities range from 34 m³/h to 34,000 m³/h
Capacities range from 20 CFM to 20,000 CFM
Multi-stage system pressures as low as 0.001 mm HgA



Service for Liquid Ring Pumps

We have the know-how, the experience and the specialists:
We provide professional service to keep your pumps running and efficient for decades. Our Service Centers are located in:

- Australia
- Brazil
- China
- Germany
- Korea
- The Netherlands
- Singapore
- South Africa
- United Kingdom
- USA



Gardner Denver Nash has many ISO 9001 certifications.



Gardner Denver Nash has an extensive network of sales offices and representatives all over Europe and the world.

ООО "БЛИМ Синержи"
107023, г. Москва, ул.
Электрозаводская, д.24
Телефон: +7 (495) 781-39-39
Факс: +7 (495) 781-35-91
(автомат.)
www: blms.ru
e-mail: rt@blms.ru